

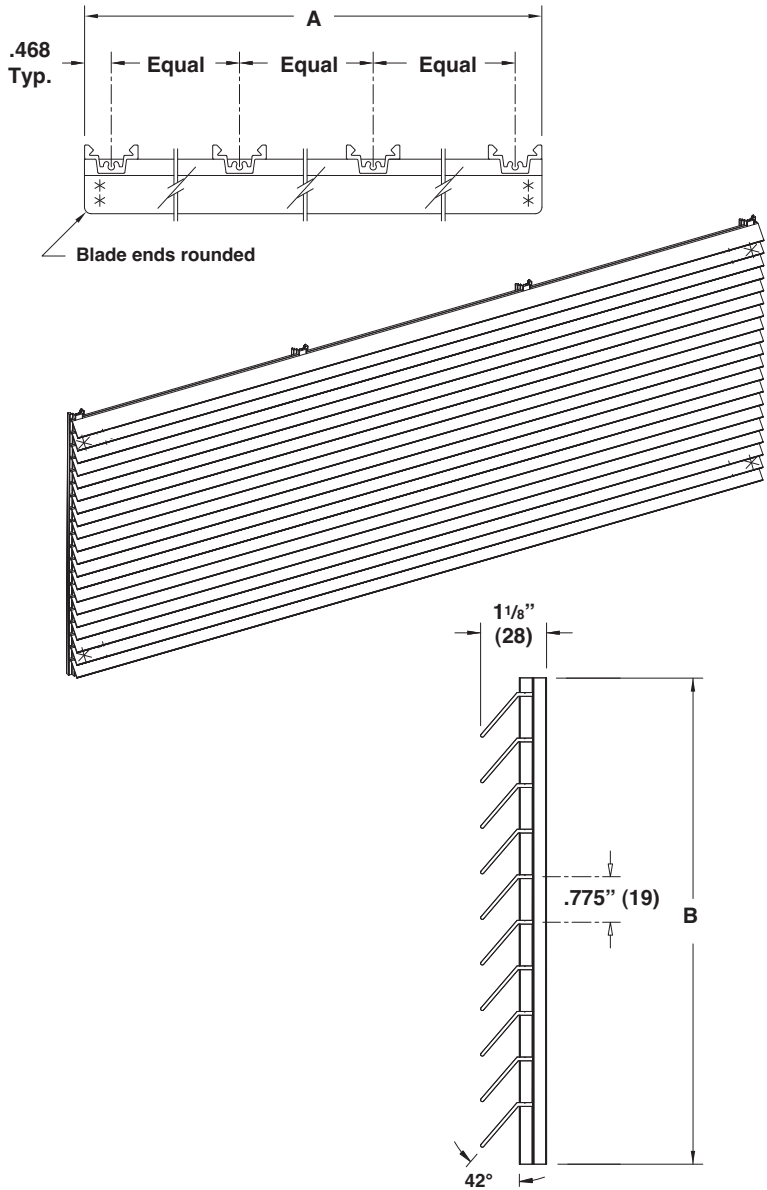

AEL - 42



STANDARD CONSTRUCTION

FRAME
 Extruded aluminum; 6063-T5; clear.
 Anodized or _____
 42° architectural decorative louver face and end views for illustration purposes only.
 A = _____
 B = _____
 A as required, not to exceed 180" (4512).
 B as required, not to exceed 84" (2134).
 Brace bar as required, not to exceed 16" (406).

BLADES
 Standard blade thickness .040 with a variety of perimeter frames available. Heavier blades available. Although the AEL-42 is primarily used in PTAC applications, it can also be constructed as a mechanical screen or a variety of aesthetic pleasing thinline applications.

VARIATIONS

Variations to the basic design of the louver are available at additional cost. They include:

- Frames of choice, see frame submittal sheet.
- 1" (25) blade spacing.
- Exterior mounting holes as required.

*Consult Reliable for other special requirements.

Dimensions in inches, parenthesis () indicate millimeters.

TAG	QTY.	ACTUAL SIZE		FRAME	VARIATIONS
		A*-WIDE	B*-HIGH		
PROJECT ARCH./ENGR. REPRESENTATIVE		 WebREPS 1-800-810-3280		LOCATION CONTRACTOR DATE	

AEL - 30

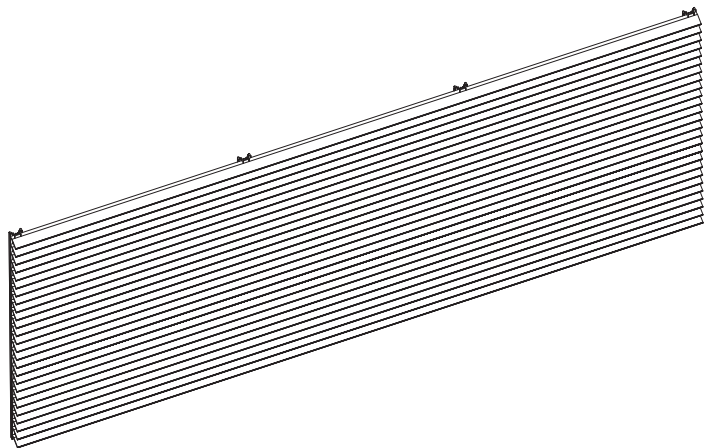
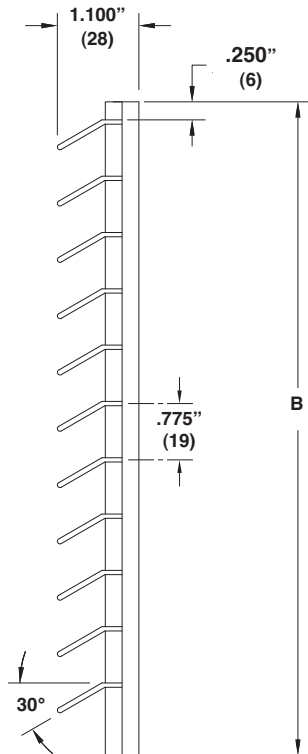
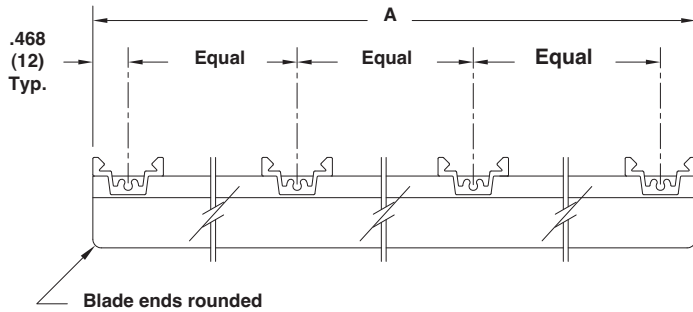

STANDARD CONSTRUCTION

- Extruded aluminum; 6063-T5
- 30° architectural decorative louver

OPTIONS

- Clear or anodized finish
- Prime coat
- Baked Enamel (Kynar 50%)
- Pearledized 50 or 70
- Kynar 70%
- Frames of choice - see frame submittal sheet

VARIATIONS

- A as required, not to exceed 190" (4826)
- B as required, not to exceed 84" (2134)
- Brace bar as required, not to exceed 16" (406)

Notes:

1. Face view for illustration purposes only.
2. Dimensions in inches, parenthesis () indicate millimeters.

QTY.	ACTUAL SIZE		VARIATIONS
	A	B	
PROJECT ARCH./ENGR. REPRESENTATIVE	 WebREPS 1-800-810-3280		LOCATION CONTRACTOR DATE



AEL - 45

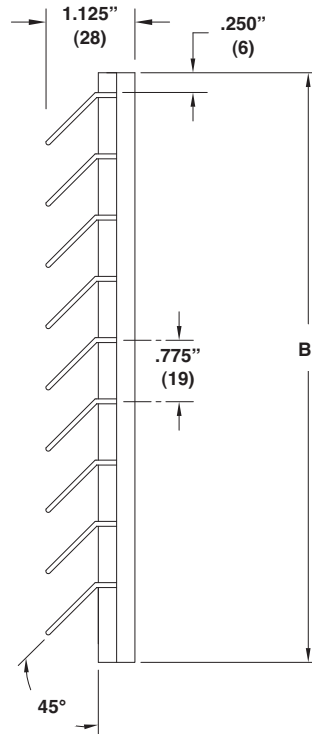
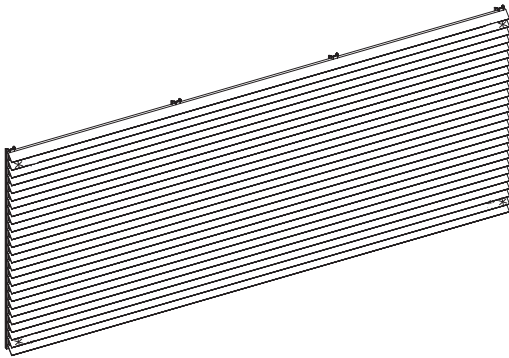
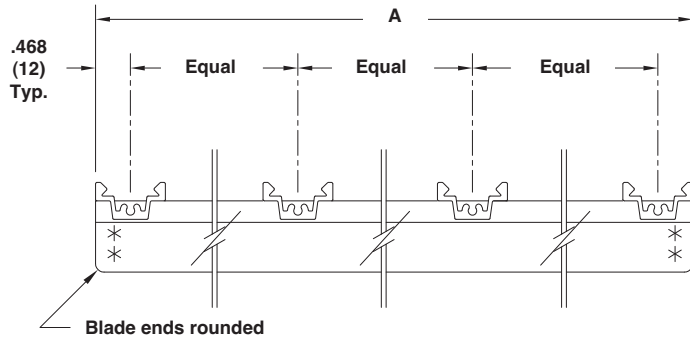

STANDARD CONSTRUCTION

- Extruded aluminum; 6063-T5
- 45° architectural decorative louver

OPTIONS

- Clear or anodized finish
- Prime coat
- Baked Enamel (Kynar 50%)
- Pearledized 50 or 70
- Kynar 70%
- Frames of choice, see frame submittal sheet

VARIATIONS

- A as required, not to exceed 180" (4512)
- B as required, not to exceed 84" (2134)
- Brace bar as required, not to exceed 16" (406)

Notes:

1. Face and end views for illustration purposes only
2. Dimensions in inches, parenthesis () indicate millimeters

*Extension mounting holes as required.

QTY.	ACTUAL SIZE		VARIATIONS
	A	B	
PROJECT ARCH./ENGR. REPRESENTATIVE	WebREPS 1-800-810-3280		LOCATION CONTRACTOR DATE



1300 ENTERPRISE ROAD GENEVA, ALABAMA 36340-0580 800-239-4621 FAX 1-800-508-1469 www.reliablelouvers.com

AEL-112

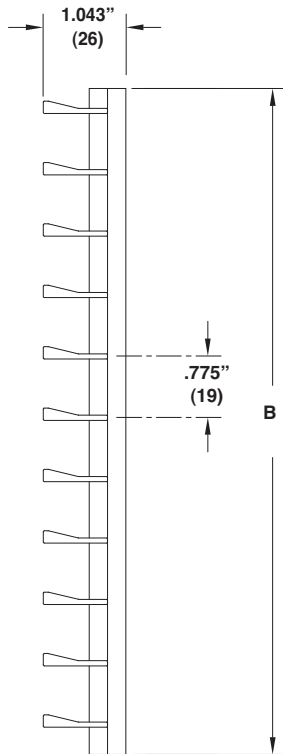
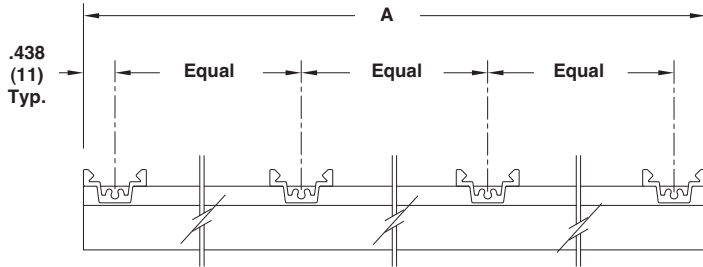

STANDARD CONSTRUCTION

- Extruded aluminum; 6063-T5
- Architectural decorative louver w/112 blade

OPTIONS

- Clear or anodized finish
- Prime coat
- Baked Enamel (Kynar 50%)
- Pearledized 50 or 70
- Kynar 70%
- Frames of choice. - see frame submittal sheet

VARIATIONS

- A as required, not to exceed 180" (4512)
- B as required, not to exceed 84" (2134)
- Brace bar as required, not to exceed 16" (406)

Notes:

1. Face and end views for illustration purposes only
2. Dimensions in inches, parenthesis () indicate millimeters

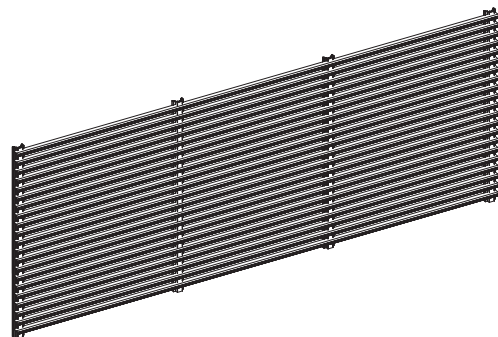

QTY.	ACTUAL SIZE		VARIATIONS
	A	B	
PROJECT ARCH./ENGR. REPRESENTATIVE	 WebREPS 1-800-810-3280		LOCATION CONTRACTOR DATE